

# Flexflo® Top Entry Regulator Model 900TE



*The Model 900TE (Top Entry) Flexflo® Regulator is a self-contained, pilot-operated pressure regulator that may be used in both gas and liquid applications. The 900TE Flexflo® Regulator design features a simple, top-entry design for easy in-line maintenance. The 900TE incorporates a cast steel body with integral flanged end connections. Multiple trim configurations are available to match a variety of applications. The 900TE Flexflo® Regulator is available from 2" (50.8 mm) to 6" (152.4 mm) bore. The 900TE Flexflo® Regulator typically is used with a Flexflo® Pilot for pressure control applications. The environmentally friendly design of the Flexflo® Pilot and Regulator eliminates all atmospheric emissions by maintaining all gas/liquid within the piping system.*

## Features:

- Top entry design provides easy in-line maintenance or inspection
- Top entry design accessible without removal of pilot or plumbing
- Rugged design ideal for demanding pipeline applications
- Pulsation resistant design ideal for power plant type applications
- No hydraulic oil or internal springs required
- Simple design has only one moving part
- Environmentally friendly design with no emissions
- Reduced capacity trims may be easily exchanged to optimize for flow conditions
- Dual instrument connection ports allow versatile control options/configurations
- Since 1942, the Flexflo® Regulator is the original flexible element regulator
- Can be mounted horizontal, vertical or upside down
- Low noise
- Pressure reducing, pressure relief or flow control applications

## Specifications:

<b>Item:</b>	Model 900TE Flexflo® Regulator
<b>Type:</b>	Pilot Operated Regulator
<b>Body Materials:</b>	WCB
<b>Available Sizes:</b>	2 in. (50.8 mm) 3 in. (76.2 mm) 4 in. (101.6 mm) 6 in. (152.4 mm)
<b>End Connections:</b>	Raised Face Flange 150, 300, 600 ANSI ASME/ANSI B16.10
<b>Working Temperature:</b>	-20°F to +150°F (-29°C to +66°C) Standard*
<b>Maximum Differential:</b>	1200 psid*
<b>Maximum Inlet Pressure:</b>	1480 psig*
<b>Outlet Pressure Range:</b>	1480 psig**

\* Limited by Flexflo® Tube Selection.

\*\* Limited by Flexflo® Pilot Selection.

**The Flexflo® Regulator is the original flexible element regulator!**

*The 900TE Flexflo® Regulator is the ideal regulator for natural gas transmission/distribution systems and power plants. The combined package of the 900TE, filter, and Model 829S1 Pilot shown here provides a reliable and economical regulation package for all your pipeline needs. The 900TE Flexflo® Regulator is capable of regulating both gas and liquids, but is most commonly utilized in natural gas pipelines.*



**The GE™ Model 900TE Flexflo® Regulator is Extremely User Friendly to Maintain**

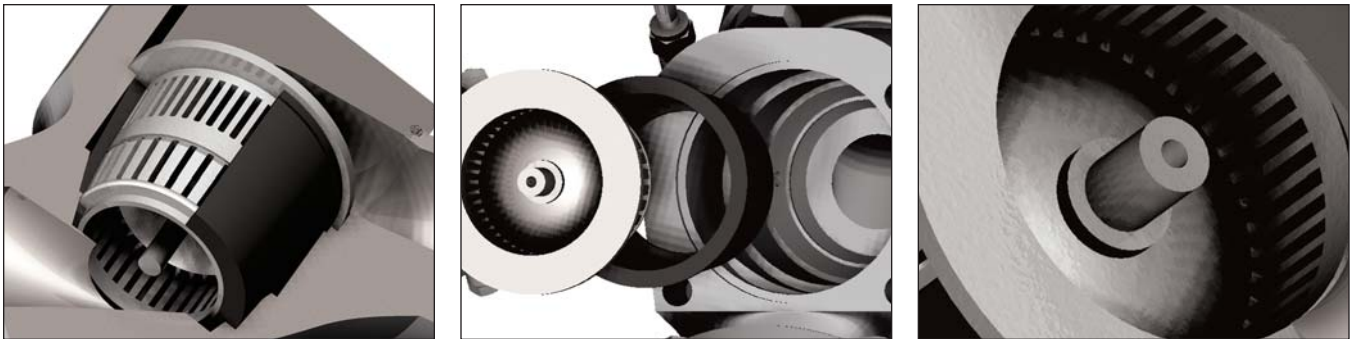

**GE™ Model 900TE Flexflo® Regulator**

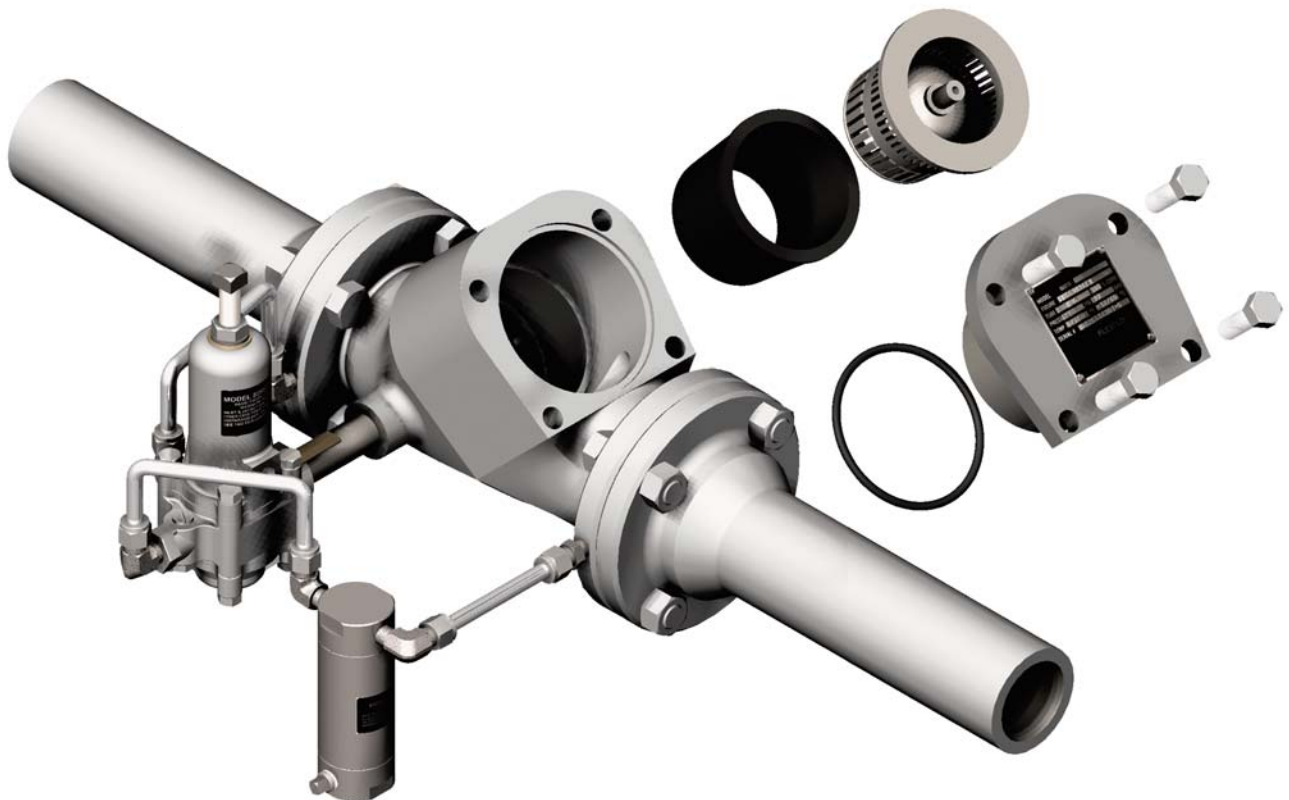

## How it Works

Operation of the 900TE Flexflo® Regulator consists of one moving part, the Tube. This single moving part is a flexible element that controls the flow of gas/liquid through the Core of the regulator. Application of Jacket Pressure to the Tube (tube shown in purple) will regulate the volume of gas/liquid that flows through the regulator.

The 900TE Flexflo® Regulator functions as a "slave" device and requires a "brain" to control the process application. Most commonly, Flexflo® Pilots are utilized as the "brain" to control the process. For information on GE™ Flexflo® Pilots and other related Flexflo® accessories, see pages 13 to 15 of this brochure.

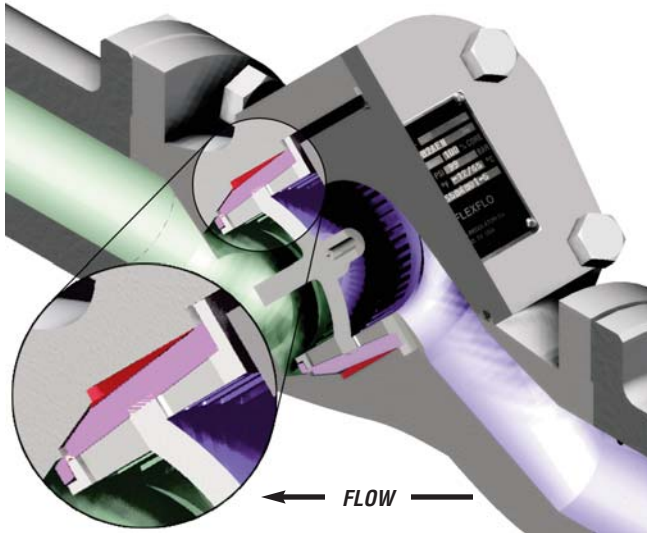

### Model 900TE Flexflo® Regulator at Full Closed Position

As Jacket Pressure is increased the Tube will constrict around the Core reducing the flow volume that passes through the Core of the regulator. If Jacket Pressure is maximized, the Tube will seal around the center sealing surface of the Core and shut off flow. Jacket Pressure is maximized when it is equal to Upstream Pressure.

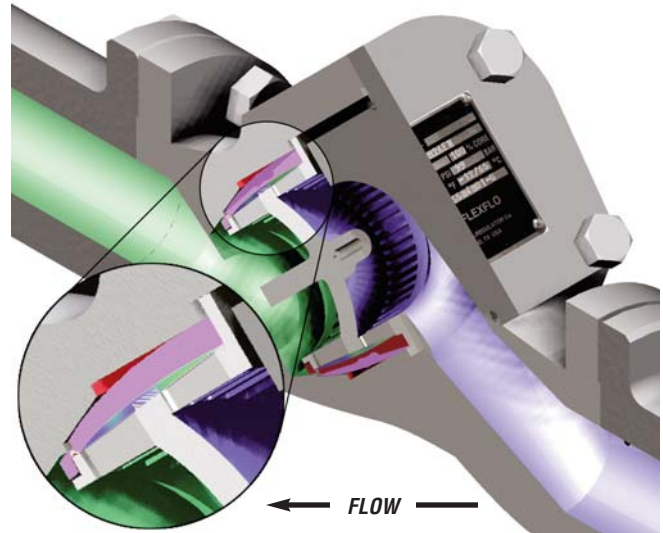

### Model 900TE Flexflo® Regulator at Full Open Position

As Jacket Pressure is decreased, the Tube will expand from the Core increasing the flow volume that passes through the regulator. If Jacket Pressure is minimized, the Tube will expand away from the sealing surface of the Core allowing maximum flow. Jacket Pressure is minimized when it is equal to Downstream Pressure.

# Flexflo

Size	ANSI Class	Face to Face (A)	Flange Diameter	Weight
2" (50.8 mm)	150	10" 254 mm	6" 152 mm	40 lbs 18 kg
	300	10.5" 267 mm	6.5" 165 mm	45 lbs 20 kg
	600	11.25" 286 mm	6.5" 165 mm	49 lbs 22 kg
3" (76.2 mm)	150	11.75" 298 mm	7.5" 191 mm	96 lbs 44 kg
	300	12.5" 318 mm	8.25" 210 mm	103 lbs 47 kg
	600	13.25" 337 mm	8.25" 210 mm	119 lbs 54 kg
4" (101.6 mm)	150	13.875" 352 mm	9" 229 mm	124 lbs 56 kg
	300	14.5" 368 mm	10" 254 mm	144 lbs 65 kg
	600	15.5" 394 mm	10" 254 mm	164 lbs 74 kg
6" (152.4 mm)	150	17.75" 451 mm	11" 279 mm	294 lbs 133 kg
	300	18.63" 473 mm	12.5" 318 mm	338 lbs 153 kg
	600	20" 508 mm	14" 356 mm	373 lbs 169 kg

**Model 900TE Flexflo® Regulator Cv  
(Flow Coefficient) Data**

Size	Max C <sub>v</sub> (100% Core)	Qmax H <sub>2</sub> O
2" (50.8 mm)	58	300
3" (76.2 mm)	94	660
4" (101.6 mm)	128.5	1175
6" (152.4 mm)	304	2644

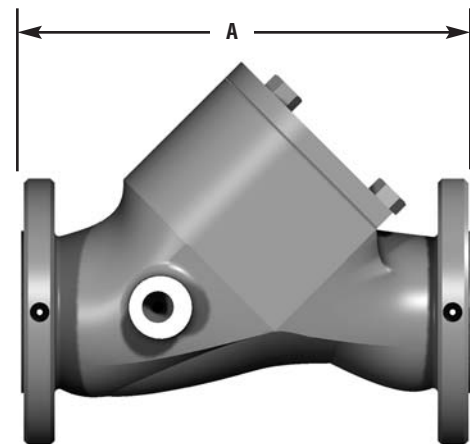

# Regulators

## Model 900TE Flexflo® Regulator Figure Number Designation

GE™ Flexflo® Regulator Model Number Designation Explanation.

Every GE regulator product can be completely identified by its figure number.

Listed below is an example of how figure numbers are derived.

**Example:** 3 in. GE™ Model 900TE Regulator, Class 150 ANSI End Connections with Hydrin 893 Tube.

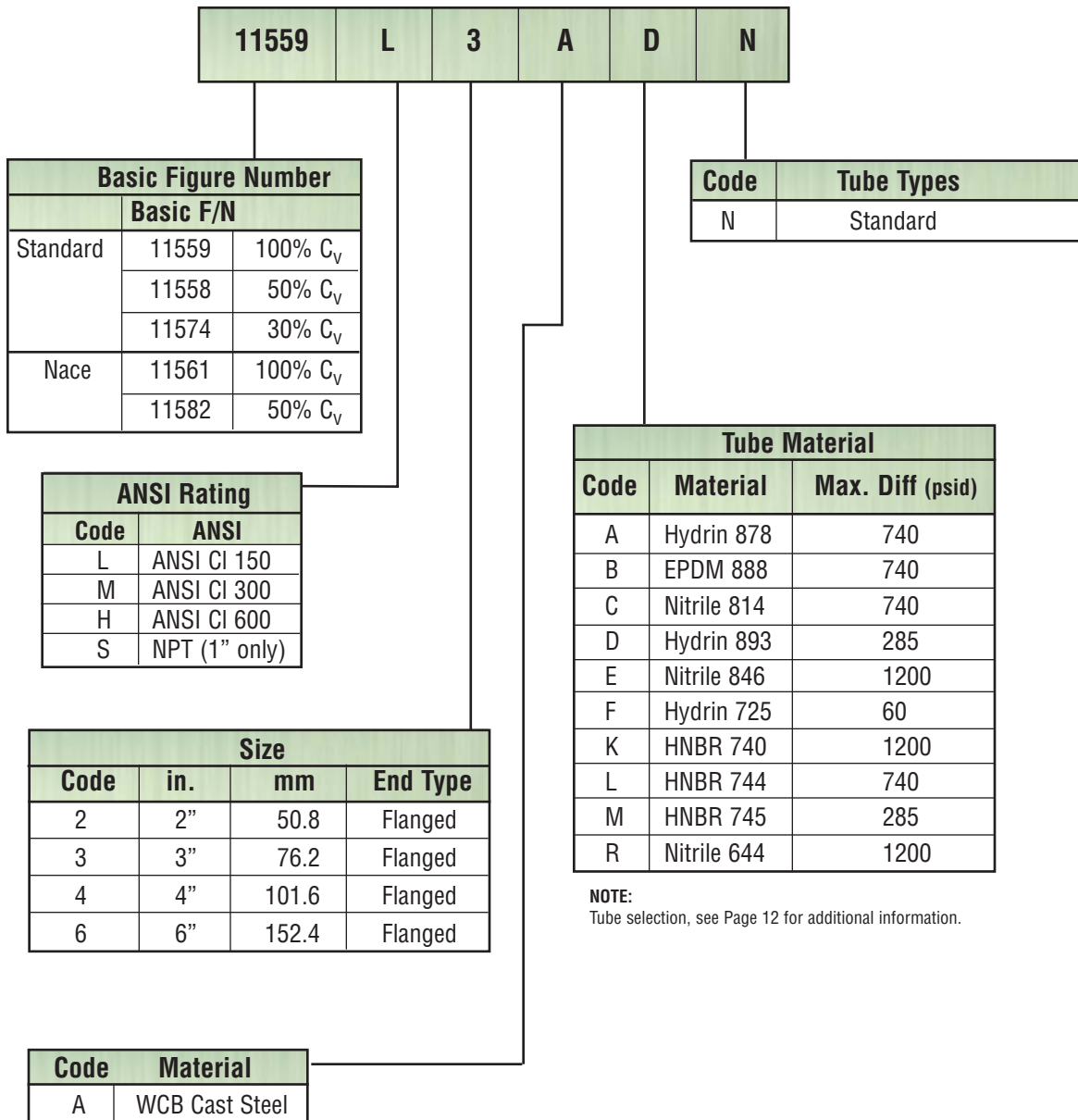



# Flexflo® Regulator Models 900TE

## GE™ Tube material selection table for Flexflo® Regulators

In order to meet the exact demands of each particular Flexflo® Application, GE product line has a wide variety of different tube compounds. When selecting a tube for a specific application, its important to take into consideration pressure differential, temperature, as well as the particular flow media. In the table below there are some of the standard tubes that are in the GE product line.

### Standard Flexflo® Tube Materials

GE Material (Code number)	814 (C)	846 (E)	878 (A)	893 (D)	888 (B)	725 (F)	745 (M) 744 (L) 740 (K)	644 (R)
Base Polymer	Nitrile	Nitrile	Hydrin	Hydrin	EPDM	Hydrin	HNBR	Nitrile
Nominal Durometer	65	75	65	55	70	40	65,75,85	75
Max. Differential (psid)	740	1200	740	285	740	60	745,744,740 285,740,1200	1200
Temp. Range min/max °F	10/150	10/150	-20/150	-40/150	-20/175	-40/120	10/212	-40/150
Temp. Range min/max °C	-12/65	-12/65	-29/65	-40/65	-29/79	-40/48	-12/100	-40/65
<i>Hydrocarbon</i>								
Gaseous	OK	OK	OK	OK	NR	OK	OK	OK
Liquid	OK	OK	OK	OK	NR	OK	OK	OK
% Aromatic content Max	20	15	30	15	NR	20	40	NR
Max sulfur % wt	0.5	0.5	5	0.5	NR	5	5	NR
Fluid Compatibility								
Water	OK	OK	NR	NR	OK	NR	OK	OK
Nitrogen	OK	OK	OK	OK	OK	OK	OK	OK
Air	OK	OK	OK	120°F max	OK	OK	OK	OK
Synthetic Lubes (Phosphate Esters)	NR	NR	NR	OK	NR	NR	NR	NR
Peroxides (Sour Gasoline)	NR	NR	NR	NR	NR	NR	OK	OK
Ketones/Amines	NR	NR	NR	NR	NR	NR	NR	NR
Max H2S in water %wt	0.5	0.5	NR	NR	Unlimited	NR	1.5	NR
Methyl. Ethyl Alcohols	NR	NR	NR	NR	OK	NR		NR
	Gen-Hydro- carbon Service, Water	Gen-Hydro- carbon Service, Water	Gen-Hydro- carbon Service	Gen-Hydro- carbon Service	Std. Water Ammonia, CO <sub>2</sub> Service	Low ΔP Apps Only	White Petrol Products, Unleaded Gas w/Alcohols (MTBE) Crude Oil	Gen-Hydro- carbon Service, Water

#### NOTES:

OK Indicates Material is Compatible with Corresponding Fluid.

NR Indicates Material Not Recommended for Specific Flexflo® Regulator Model.

Nitrile, Hydrin and HNBR are standard.

*Suggestion only: Customer must choose best tube for the application.*

Hydrin is a registered trademark of Zeon Chemicals L.P.

# GE™ Regulators Has The Optimum Flexflo® Pilot For Your Regulator Applications

**Legend**  
 Recommended Operating Range  
 Total Operating Range

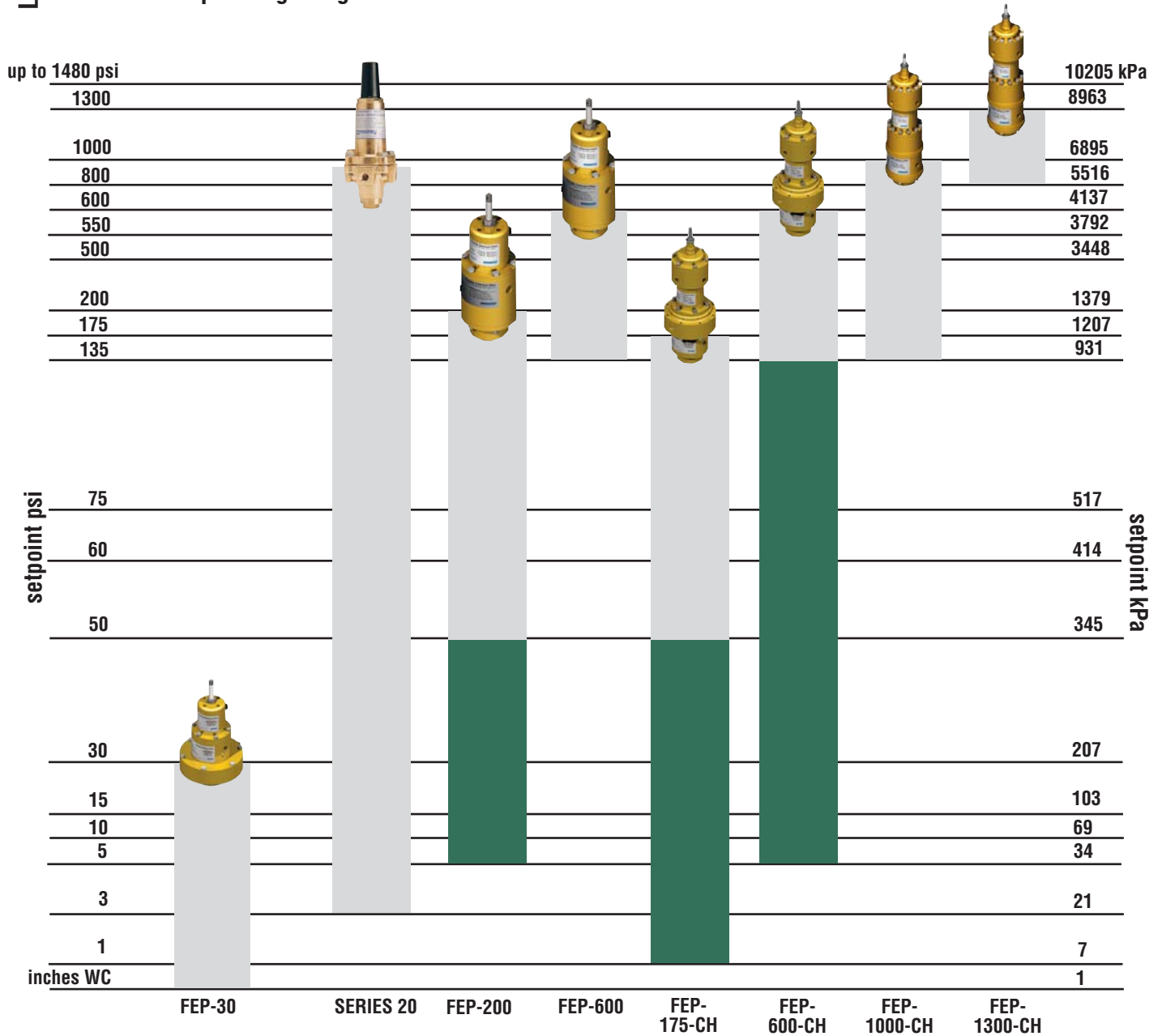

# Flexflo

Please call Dresser Becker Precision Equipment at 1-800-323-8844 for additional information on the FEP Products.

## Flexflo® Regulator Accessories/Options

Realize Optimum Performance of your Flexflo® Regulator with these popular accessories/options!



### FEP-30 Becker Pilot (Low Pressure/High Accuracy Applications)

The FEP-30 Pilot is a reversible pressure control pilot (seat & nozzle design) that is used in conjunction with Flexflo® Regulators to provide pressure control. The FEP-30 Pilot is typically utilized in low-pressure natural gas distribution systems. The FEP-30 features accuracy and sensitivity to provide unrivaled control accuracy for setpoints ranging from inches H<sub>2</sub>O to 30 psig (1.0-207 kPa). The FEP-30 features a large convoluted sensing diaphragm and friction-free design that provides superior sensitivity at critical low-pressure setpoints. Additionally, note that the FEP-30 Series Pilots feature a submersible design that is ideally suited for vault applications that may fill with water.

**Control Range:** in w.c. 30 psig (1.0 - 206 kPa)

**Available Action:** Pressure Reducing  
Back Pressure/Relief

**Available Models:** FEP-30

**Flow Media:** Gas

**Dimensions:** 8.375" x 6" diameter  
(213mm x 152mm diameter)

**Compatible**

**Regulators:** 900 TE Flexflo® Regulators

**Weight:** 6 lbs (2.7 kg)

**Temp. Range:** -20°F to 160°F (-29°C to 71°C)

### 20, 20H, 20HS Mooney® Pilot (Versatile Regulation)

The Series 20™ Flowgrid® pilot is a reversible pressure-control regulator designed primarily for use as a control pilot with unloading-type pilot systems for pressure-reducing (PRV), backpressure (BPV or Relief), and differential-pressure (DPV) applications. The Series 20 pilot is designed for both gas and liquid applications.

**Control Range:** 3-900 psi (21-6206 kPa)

**Available Action:** Pressure Reducing  
Back Pressure/Relief

**Available Models:** 20, 20H, 20HS

**Flow Media:** Gas and Liquids

**Dimensions:** 8.9" x 3" x 3"  
(226mm x 76mm x 76mm)

**Compatible**

**Regulators:** 900 TE Flexflo® Regulators

**Weight:** 6 lbs (2.24 kg)

**Temp. Range:** -20°F to 150°F (-29°C to 65°C)





## Flexflo® Regulator Accessories/Options

Realize Optimum Performance of your Flexflo® Regulator with these popular accessories/options!



### FEP-175/600-CH Becker Pilot Ultimate Performance (Power Plant Applications)

The FEP-175/600-CH Pilot is a reversible pressure control pilot (seat & nozzle design) that is used in conjunction with Flexflo® Regulators to provide pressure control. The FEP-175/600-CH is typically utilized for high performance pressure control applications such as power plants. Applications include: pressure reduction, monitor regulators, backpressure control, and relief valves. The FEP features a friction-free design, sensitive sensing diaphragm, high sensitivity and minimal droop. Additionally, note that the FEP-175/600-CH Pilot is a submersible design that is ideally suited for vault applications that fill with water.

**Control Range:** 1-600 psig (7-4137 kPa)

**Available Action:** Pressure Reducing  
Back Pressure/Relief

**Available Models:** FEP-175-CH, FEP-600-CH

**Flow Media:** Gas

**Dimensions:** 14.625" x 3.75" diameter  
(371mm x 95mm diameter)

**Compatible**

**Regulators:** 900 TE Flexflo® Regulators

**Weight:** 12 lbs (5.4 kg)

**Temp. Range:** -20°F to 160°F (-29°C to 71°C)



### FEP-1000/1300-CH Becker Pilot (High Pressure Setpoint Applications)

The FEP-1000-CH and FEP-1300-CH Pilots are reversible pressure control pilots (seat & nozzle design) that are used in conjunction with Flexflo® Regulators to provide pressure control. The FEP-1000/1300-CH Pilots are typically utilized in pipeline pressure control applications for "high pressure" setpoints up to 1300 psig (8963 kPa). Applications include pressure reduction, monitor regulator, backpressure control, and relief valves. The FEP-1000/1300-CH features improved accuracy and droop characteristics over standard issue flexible element pilots. The FEP-1000/1300-CH features a friction-free design that provides excellent sensitivity, minimal droop, and good lockup characteristics. Additionally, note that the FEP-1000/1300-CH Pilots feature a submersible design that is ideally suited for vault applications that may fill with water. The FEP-1000-CH and FEP-1300-CH are easily field reversible and supersede GE Pilot Models 820 and 830.

**Control Range:** 500-1300 psig (3448-8963 kPa)

**Available Action:** Pressure Reducing  
Back Pressure/Relief

**Available Models:** FEP-1000-CH, FEP-1300-CH

**Flow Media:** Gas

**Dimensions:** 15.375" x 4.0" diameter  
(391mm x 102mm diameter)

**Compatible**

**Regulators:** 900 TE Flexflo® Regulators

**Weight:** 13 lbs (5.9 kg)

**Temp. Range:** -20°F to 160°F (-29°C to 71°C)



### FD-1500 Becker Filter-Dryer

The Model FD-1500 Filter Dryer filters and dehydrates supply gas for use upstream of Flexflo® Pilots and other Flexflo® instrumentation. Designed for use with all pneumatic instrumentation, the FD-1500 Filter Dryer provides superior filtration and dehydration with 110 square iEDes of 10 micron filtering media and 2.0 pounds of silica gel. The FD-1500 incorporates an easy-to-replace "spin on" cartridge made up of a high quality, high capacity nylon and fiberglass filter element reinforced with stainless steel mesh. All FD-1500's are fully hydrotested to 2.5 times the working pressure to ensure the integrity of the pressure vessel. Model FD-1500 Filter-Dryers are PED Compliant (Restrictions apply).

**MAOP:** 1500 psig (10,340 kPa)\*  
all units hydrotested to  
2250 psig (15,510 kPa)

**Max. Temp:** 200°F (93°C)

**Filtration:** 10 µ nominal (110 in<sup>2</sup>  
filtration media)

**Dehydration:** 2 lbs. (0.9kg) silica gel  
water absorption

**Inlet/Outlet Port:** 1/4" FNPT 1.75"

**Drain:** 1/4" FNPT with plug

**Dimensions:** 20" (508 mm) length x 4-1/2"  
(44 mm) diameter

**Mounting:** Panel Mount or 2" Pipe Mount

**Weight:** 29 lbs. (5.0 kg)

## Application Guidelines for Flexflo® Regulators

Model 900TE	
<b>Applications</b>	
Pressure Control	•
Power Plant Control	•
Monitor Regulator (Overpressure)	•
Relief Service (Overpressure)	•
Flow Control	•
Line Break Protection	•
Backpressure Control	•
On-Off Service	•
Liquid Surge Relief <sup>1</sup>	
<b>Features</b>	
In-Line “Top Entry” Maintenance	•
Water-Style Compact Design	
NACE Compliant	•
All Stainless Steel Construction	
Optional Reduced Capacity Trims	•
<b>Available Configurations</b>	
1” (25.4 mm) Bore	
1.5” (38.1 mm) Bore	
2” (50.8 mm) Bore	•
3” (76.2 mm) Bore	•
4” (101.6 mm) Bore	•
6” (152.4) Bore	•
<b>End Connections</b>	
Flangeless (Wafer)	
Raised Face Flanged End	•
Screwed <sup>2</sup>	
<b>Flexflo Regulator Accessories/Option</b>	
FEP-30 Becker Pilot	•
FEP 200/600 Becker Pilot	•
FEP-175/600-CH Becker Pilot	•
FEP-1000/1300-CH Becker Pilot	•
<b>NOTES:</b>	
<sup>1</sup> Model 900TE Flexflo® Regulators may be utilized as an economical option for Liquid Relief. Model 887 Flexflo® Surge Relievers are the primary choice for Liquid Surge Relief due to speed of response.	
<sup>2</sup>	
<b>NOTE: This information is intended as a guideline for application of GE™ Flexflo® Products. We reserve the right to modify product design at any time without notice. We strongly recommend contacting GE Regulator Operations prior to application of any products.</b>	

# Flexflo